

PART NO.: I-KC301

Dimension: 80mmx80mm

DESCRIPTION: 304 Stainless steel frame touchpad

MAIN FEATURE

Faceplate Dimensions: 80mmx80mm

Touchpad Dimension: 65mmx49mm

Dustproof, Water proof, Vandalism resistance, Shakeproof, Pickproof

Key travel: 0.45mm.

keyswitch lifetime: > 10 million of operations.

G.W: 0.25kg.

TECHNICAL DATA

- Lifespan :> 5 years.
- Interface: PS2, USB available.
- Supply Voltage: 5V DC
- Protection Level: IP65;NEMA4X
- Operating temperature:-10C to +60C.
- Storage temperature: -20C to +70C.
- CERT: RoHS, CE and FCC.



HMI Components Division
Diamond Electronics Limited



+44 (0) 1477 505206
+44 (0) 1477 500656
sales@diamondhmi.co.uk
www.diamondhmi.co.uk

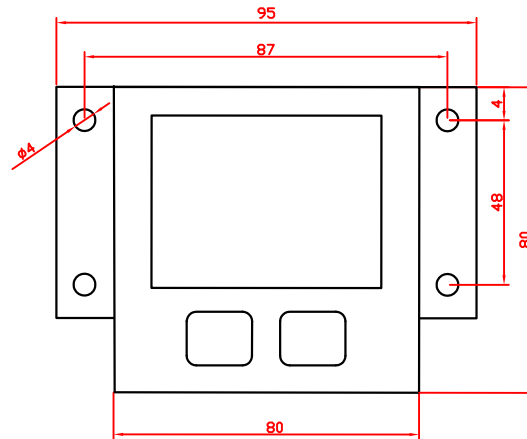
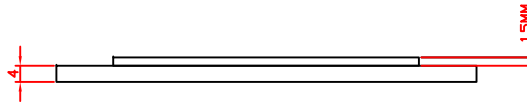

HMI Components Division
Diamond Electronics Limited



+44 (0) 1477 505206
+44 (0) 1477 500656
sales@diamondhmi.co.uk
www.diamondhmi.co.uk



HMI Components Division
Diamond Electronics Limited



+44 (0) 1477 505206

+44 (0) 1477 500656

sales@diamondhmi.co.uk

www.diamondhmi.co.uk