

# RoHS

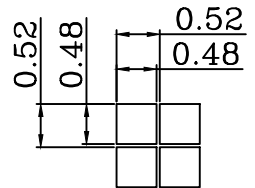

DOTS SIZE

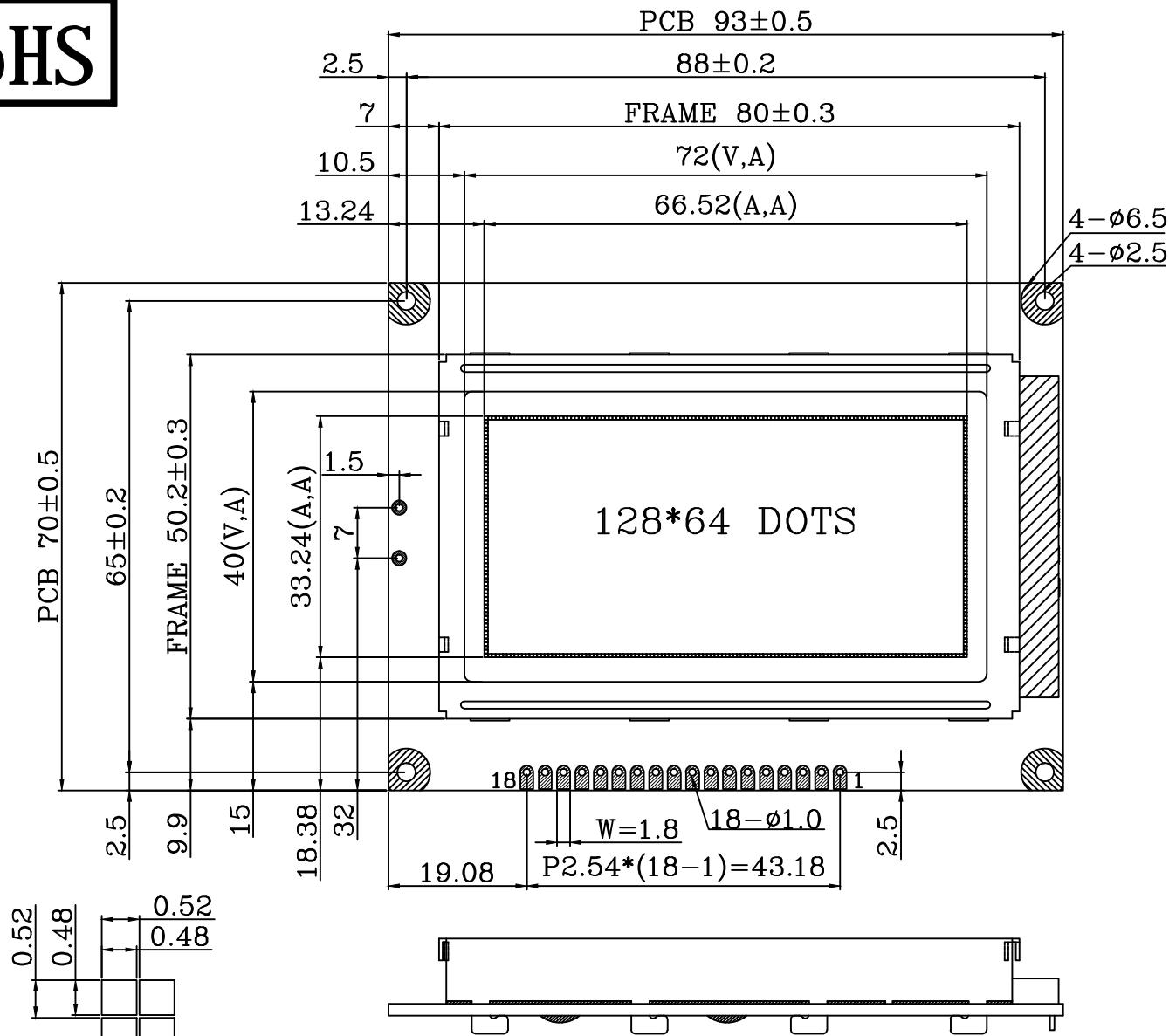
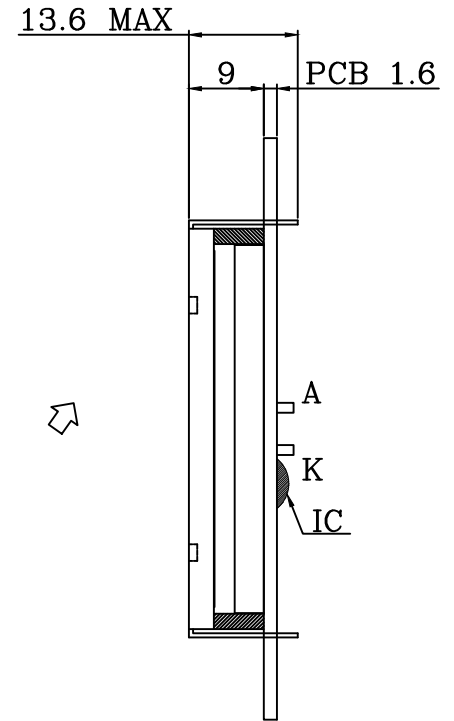

NO	NAME
1	VSS
2	VDD
3	NC
4	RS
5	R/W
6	E
7	DB0
8	DB1
9	DB2
10	DB3
11	DB4
12	DB5
13	DB6
14	DB7
15	A
16	K
17	REST
18	Vout

NOTES:

- DRIVE METHOD: 1/32DUTY, 1/5BIAS, VOP4.5V, VDD 3.3V.
- VIEWING ANGLE: 6 O'CLOCK. 封口在右.
- DISPLAY TYPE: STN(Y/G), TRANSFLECTIVE/POSITIVE.
- OPERATING TEMP: -20 TO 70°C.
- STORAGE TEMP: -30 TO 80°C.
- CONNECTION: ZEBRA, Large panel is on top layer.
- BACK LIGHT: WHITE, (VF=3.8V, IF=80mA (3020 x 4 LED))
- IC: ST7920-0B, ST7921.
- WITH DC DC.
- R7 TO 0Ω, R1 TO 15KΩ~16KΩ
- NOT DIMENSION TOLERANCES IS ±0.3.

日期	版本	修改内容
20170330	01	修改公司抬頭為"晶發科技股份有限公司"



晶發科技股份有限公司  
GI FAR TECHNOLOGY CO., LTD

DATE	2017.03.30	REV	01
UNIT : mm	Product :	GFE128064N-YPFE-01	
SCALE : 1/1	DRAWN :	Hazel	CHECKED : Kevin
SHEET : 1/1			PAGE : 1/1