

PART NO.: I-KB010

Dimension: 400x124mm

DESCRIPTION: 304 Stainless steel keyboard with integrated trackball

MAIN FEATURE

- Dimensions: 400mm x 124mm (front panel)
- Dustproof, Water proof, Vandalism resistance
- Mounting type: Front Mounting
- No. of keys: 66 keys, high quality stainless steel.
- Track ball diameter: 38mm
- Keyswitch Technology: Silicone switching element
- keyswitch lifetime: > 5 million of operations.
- Actuation Force/travel: 1N/2.0mm
- Mounting Rack: Aluminum alloy.
- Lettering: laser engraved legends for excellent durability
- G.W. 1.80kg.

TECHNICAL DATA

- Protection Level: IP65; NEMA4X
- Lifespan: > 5 years.
- Interface: PS2, USB available.
- Supply Voltage: +5V DC +/-5%
- Operating temperature:-10C to +60C.
- Storage temperature: -20C to +70C.
- RoHS, CE and FCC.

All languages version and interface are available on request.



HMI Components Division
Diamond Electronics Limited



+44 (0) 1477 505206
+44 (0) 1477 500656
sales@diamondhmi.co.uk
www.diamondhmi.co.uk

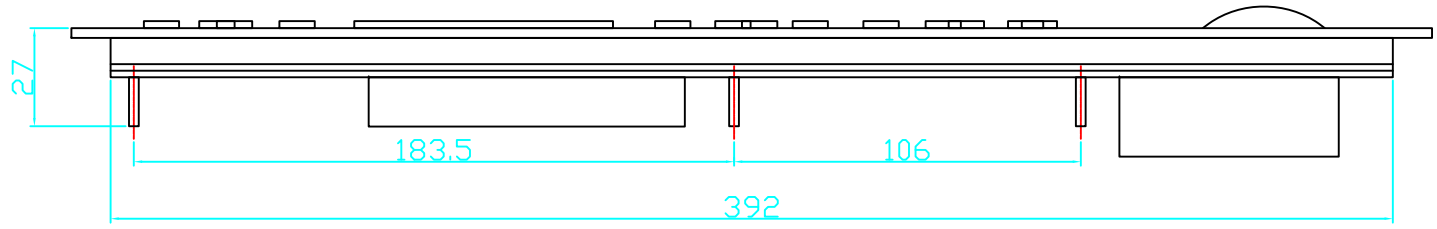
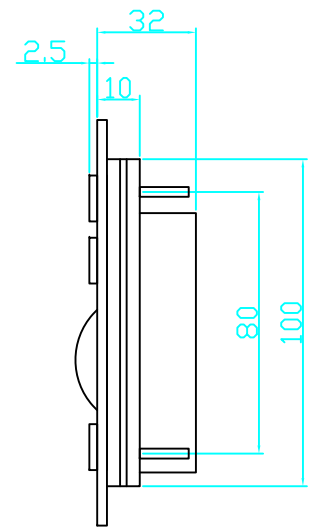
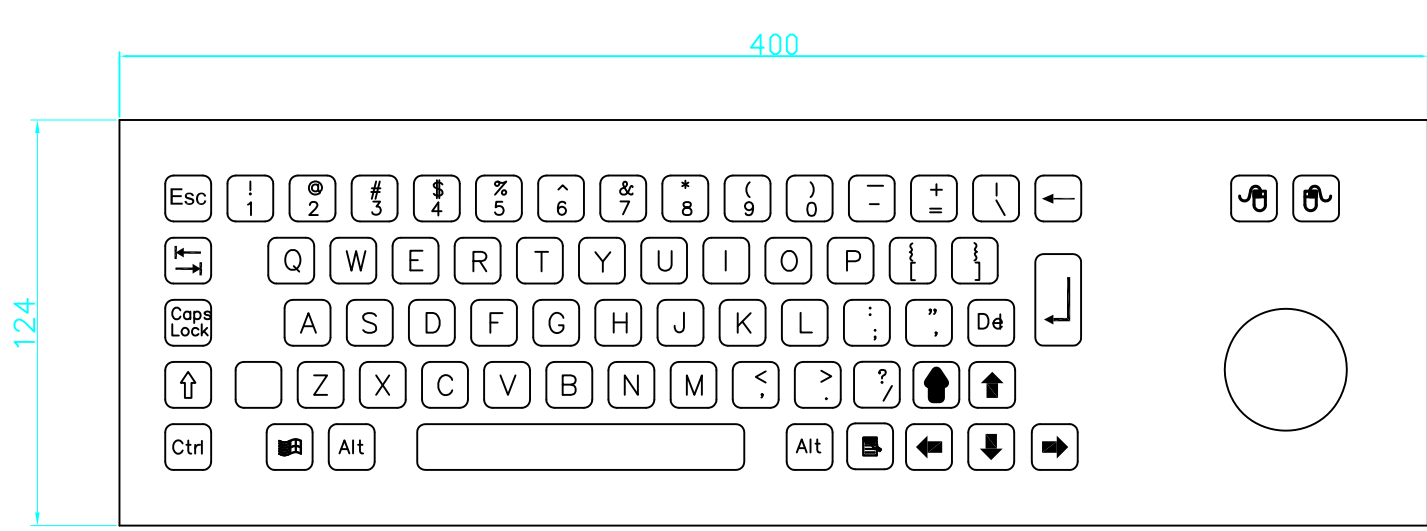

KB010



HMI Components Division
Diamond Electronics Limited

+44 (0) 1477 505206
+44 (0) 1477 500656
sales@diamondhmi.co.uk
www.diamondhmi.co.uk



mm

Inputel Technology
Co.,Ltd



HMI Components Division
Diamond Electronics Limited



+44 (0) 1477 505206

+44 (0) 1477 500656

sales@diamondhmi.co.uk

www.diamondhmi.co.uk