



WINSTAR Display Co.,Ltd.
華凌光電股份有限公司



SPECIFICATION

MODULE NO.: TST0003R5L3111XXXX00

General Specification

1. Construction:

Construction	Materials	Comment
Cover Glass	Toughened glass	Thickness: 0.7mm ± 0.05mm
ITO FILM	ITO	Thickness: 0.125mm ± 0.05mm
Optical clear adhesive	Adhesive	Thickness: 0.1mm ± 0.01mm
ITO FILM	ITO	Thickness: 0.125mm ± 0.05mm
Optical clear adhesive	Adhesive	Thickness: 0.05mm ± 0.01mm

2. Mechanical characteristics:

Item	Description	Unit
Touch Module Size	3.5	inch
Outer Dimension(with PET LENS)	76.25(W)*63(L)	mm
View Area	71(W)*53(L)	mm
Sensor Area	72(W)*54(L)	mm
Touch Module trace number(Tx*Ty)	11*8	
Resolution	896*640	
Input Type	IIC	
Control Type	FT5426DQ8	

Interface Pin Function

NO.	Pin Name
1	VSS
2	VDDT
3	SCL
4	NC
5	SDA
6	NC
7	RST
8	NC
9	INT
10	VSS

Contour Drawing

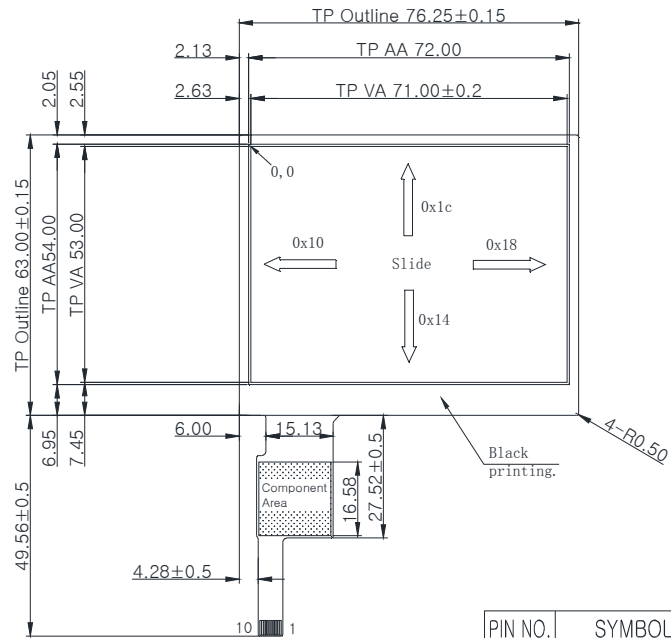

FRONT VIEW

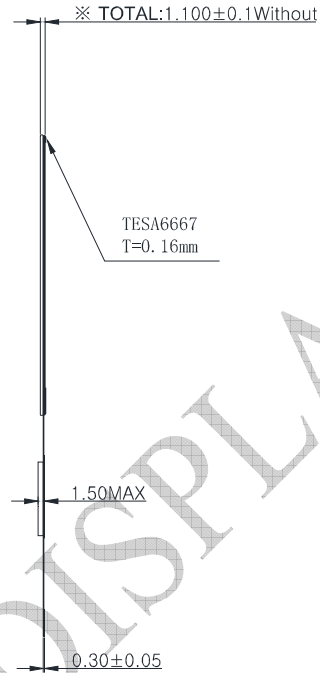

SIDE VIEW

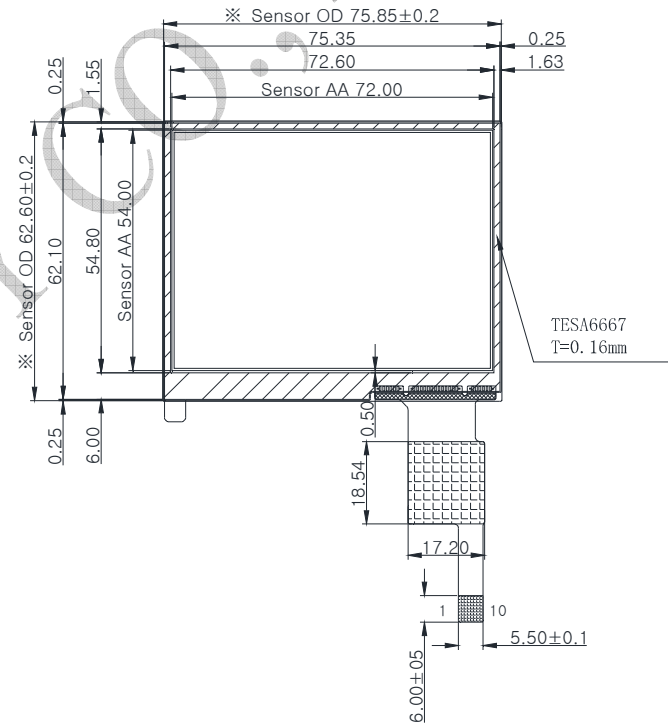

BACK VIEW

PIN NO.	SYMBOL
1	VSS
2	VDDT
3	SCL
4	NC
5	SDA
6	NC
7	/RST
8	NC
9	/INT
10	VSS

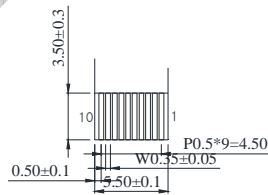

A SCALE: 3/1

The non-specified tolerance of dimension is $\pm 0.2\text{mm}$.