



WINSTAR Display Co.,Ltd.
華凌光電股份有限公司



Winstar Display Co., LTD

華凌光電股份有限公司



WEB: <http://www.winstar.com.tw> E-mail: sales@winstar.com.tw

SPECIFICATION

MODULE NO.: WF101FSYAPLNGO#

General Specifications

Item	Dimension	Unit
Screen Diagonal	10.1	inch
Number of Pixels	1280 x 3(RGB) x 800	dots
Module dimension	257.96 x 168.6 x 9.48	mm
Active area	216.96 (H) x 135.6(V)	mm
Pixel pitch	0.1695 x 0.1695	mm
Display Mode	Normally Black	
Pixel Arrangement	R.G.B. Vertical Stripe	
Backlight Type	LED, Normally White	
Aspect Ratio	16:9	
Electrical Interface (Logic)	LVDS	
Touch Panel	With PCAP	
Surface	Glare	

*Color tone slight changed by temperature and driving voltage.

Absolute Maximum Ratings

Item	Symbol	Min	Typ	Max	Unit
Operating Temperature	TOP	-20	—	+70	°C
Storage Temperature	TST	-20	—	+70	°C

Electrical Characteristics

Typical Operation Conditions

Item	Symbol	Values			Unit
		Min.	Typ.	MAX.	
Power voltage	VDD	2.3	2.5	2.7	V
	AVDD	8.0	8.2	8.4	V
	VGH	21.7	22	22.3	V
	VGL	-7.3	-7	-6.7	V
Input signal voltage	VCOM	2.7	3.0	3.3	V
Supply Voltage For Touch Logic	VDDT	2.8	-	3.3	V

Interface

Interface Connector

A 40pin connector is used for the module electronics interface. The recommended model is F62240-H1210B manufactured by Vigorconn.

Pin No.	Symbol	I/O	Function
1	VCOM	P	Common Voltage
2	VDD	P	Power Supply
3	VDD	P	Power Supply
4	NC	-	No connection
5	NC	-	No connection
6	NC	-	No connection
7	GND	P	Ground
8	Rxin0-	I	-LVDS Differential Data Input
9	Rxin0+	I	+LVDS Differential Data Input
10	GND	P	Ground
11	Rxin1-	I	-LVDS Differential Data Input
12	Rxin1+	I	+LVDS Differential Data Input
13	GND	P	Ground
14	Rxin2-	I	-LVDS Differential Data Input
15	Rxin2+	I	+LVDS Differential Data Input
16	GND	P	Ground
17	RxCLK-	I	-LVDS Differential Clock Input
18	RxCLK+	I	+LVDS Differential Clock Input
19	GND	P	Ground
20	Rxin3-	I	-LVDS Differential Data Input
21	Rxin3+	I	+LVDS Differential Data Input
22	GND	P	Ground
23	NC	-	No connection
24	NC	-	No connection
25	GND	P	Ground
26	NC	-	No connection
27	NC	-	No connection
28	NC	-	No connection

29	AVDD	P	Power for Analog Circuit
30	GND	P	Ground
31	NC	-	No connection
32	NC	-	No connection
33	NC	-	No connection
34	NC	-	No connection
35	VGL	P	Gate OFF Voltage
36	NC	-	No connection
37	NC	-	No connection
38	VGH	P	Gate ON Voltage
39	NC	-	No connection
40	NC	-	No connection

I: input, O: output, P: Power

PCAP PIN Definition

Pin	Symbol	Function
1	SDA	I2C data input and output
2	SCL	I2C clock input
3	RST	External Reset, Low is active
4	INT	External interrupt to the host
5	VDDT	Power Supply : +3.3V
6	GND	Ground for analog circuit

Contour Drawing

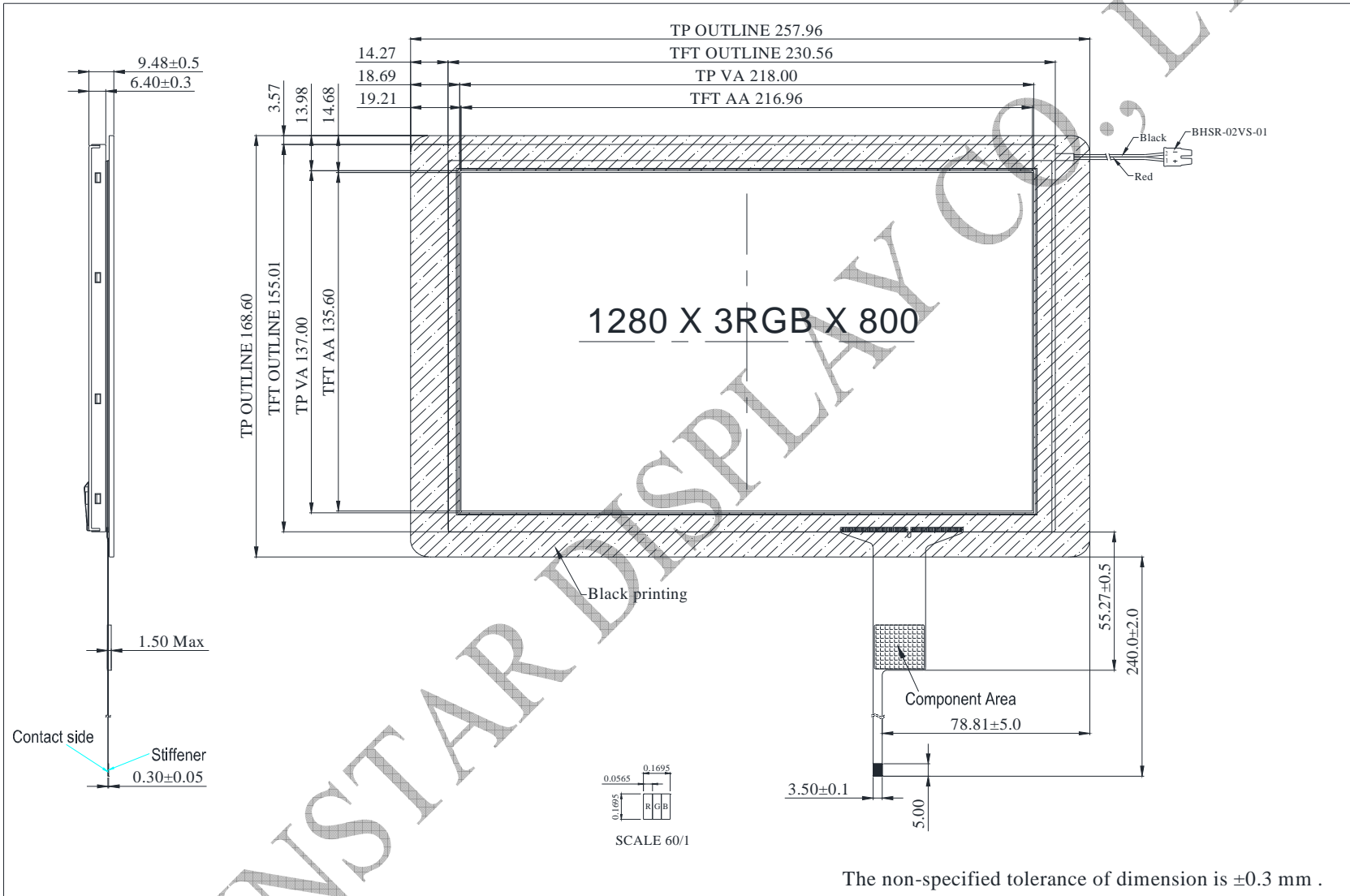

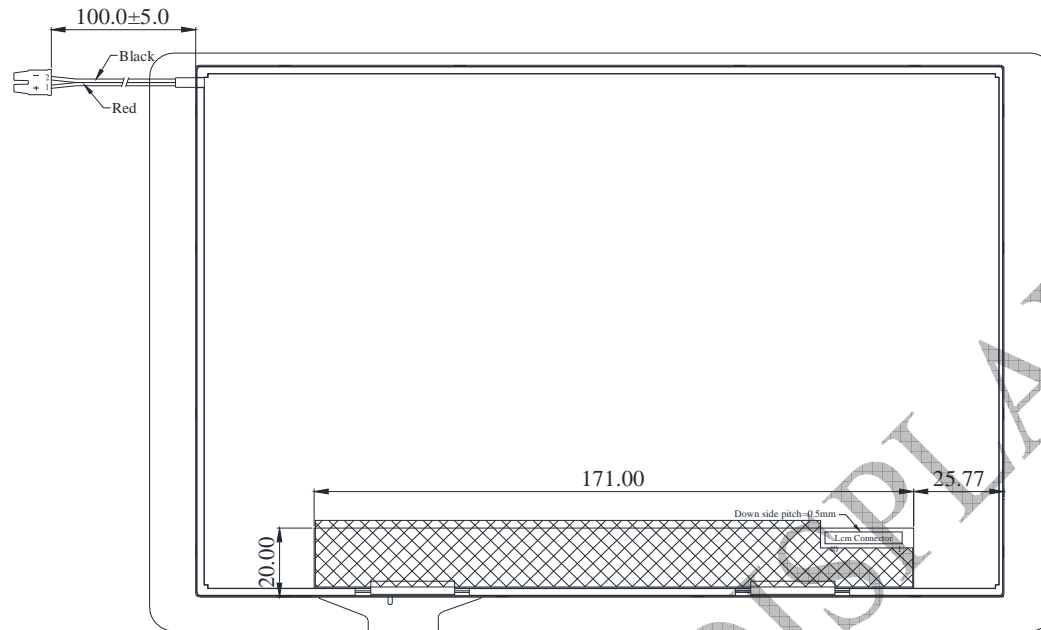

EMI
Electromagnetic shielding
film double ground

PIN NO.	SYMBOL
1	LED+
2	LED-

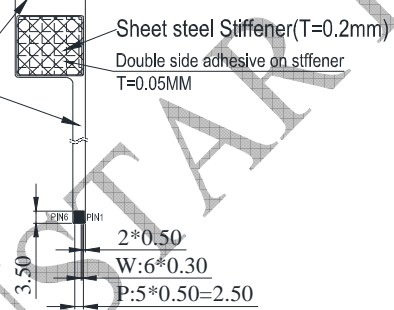

PIN NO.	SYMBOL
1	SDA
2	SCL
3	RST
4	INT
5	VDDT
6	GND

The non-specified tolerance of dimension is ± 0.3 mm .

PIN NO.	SYMBOL	PIN NO.	SYMBOL
1	VCOM	21	Rxin3+
2	VDD	22	GND
3	VDD	23	NC
4	NC	24	NC
5	NC	25	GND
6	NC	26	NC
7	GND	27	NC
8	Rxin0-	28	NC
9	Rxin0+	29	AVDD
10	GND	30	GND
11	Rxin1-	31	NC
12	Rxin1+	32	NC
13	GND	33	NC
14	Rxin2-	34	NC
15	Rxin2+	35	VGL
16	GND	36	NC
17	RxCLK-	37	NC
18	RxCLK+	38	VGH
19	GND	39	NC
20	Rxin3-	40	NC